

# AUDIOVOX<sup>®</sup>

## OWNER'S MANUAL AND INSTALLATION GUIDE

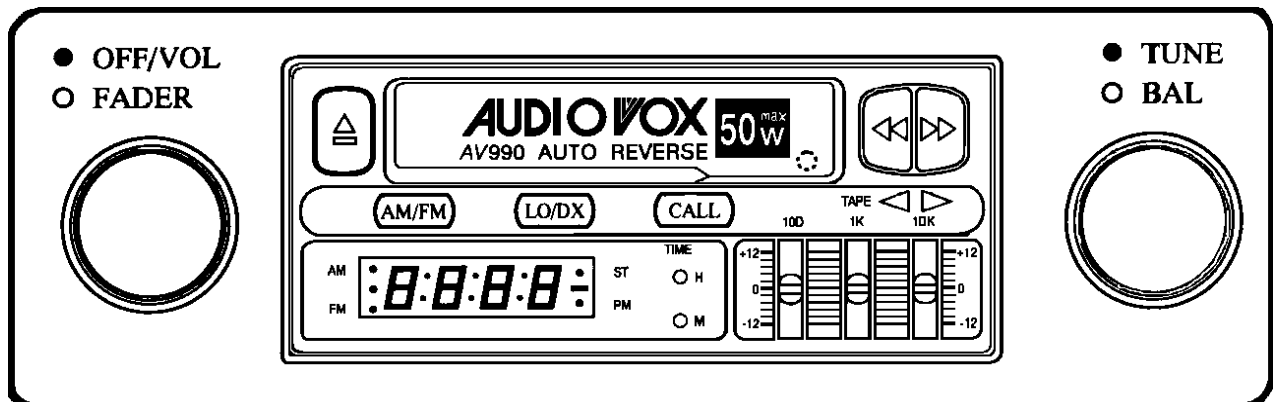

## AV990

DIGITAL AM/FM/MPX RADIO WITH  
AUTO-REVERSE CASSETTE PLAYER  
3-BAND GRAPHIC EQUALIZER  
AND QUARTZ CLOCK

## INDEX

How To Use This Manual .....	Page 1
Kit Information .....	Page 2
Universal and Import Car Installations .....	Pages 3,4
Chevrolet-Oldsmobile-Pontiac-Buick-GMC-Cadillac-Saturn Installations.....	Pages 5,6
Ford-Lincoln-Mercury Installations .....	Pages 7,8
Chrysler-Dodge-Plymouth Installations .....	Page 9
Radio Wiring .....	Page 10
Speaker Wiring- 2 Speaker Systems.....	Page 11
4 Speaker Systems.....	Page 12
Operating Instructions .....	Pages 13-15
Setting the Clock .....	Page 15
Specifications .....	Page 16
Troubleshooting .....	Page 17
Care and Maintenance .....	Page 18
Warranty .....	Back Cover

### Toll-Free Assistance

The installation and wiring connections for this unit are so simple, we doubt you'll need our help, but, if you do, we're here to help you. Just call our toll-free assistance line at **(800) 645-7102** during days/hours shown.

DAY	TIME ZONE			
	PACIFIC	MOUNTAIN	CENTRAL	EASTERN
MON.-FRI.	5:30AM - 4PM	6:30AM - 4PM	7:30AM - 6PM	8:30AM - 7PM
SATURDAY	6AM - 2PM	7AM - 3PM	8AM - 4PM	9AM - 5PM

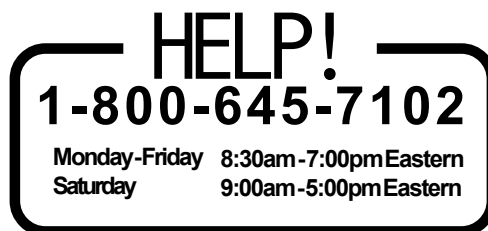

### HOW TO USE THIS MANUAL

1. Identify the make and year of the car in which you will be installing this sound system.
2. Refer to the Kit Listing and Kit Information sections on page 2 to determine if a kit is required.
3. If a kit is required, follow the directions in Kit Information section.
4. Follow the specific installation instructions for your particular make of car as listed in the index.

## KIT INFORMATION

1. The years shown in the Kit Listing below are approximate. Always check the application chart at your retail store to find information on your specific make, model, and year of vehicle. If a kit is required, read the description on the kit you intend to purchase to make sure it applies to your vehicle. If you have any doubts or questions, call our toll-free "HELP" line.
2. The kits shown below are Audiovox kits. Your retailer may sell kits made by other manufacturers which may also be usable to install this radio. Always check the kit application before purchasing it to make sure it will work with your vehicle.
3. If you believe you need a kit but cannot find a retail store where it is available, call our toll-free "HELP" line.

## KIT LISTING

VEHICLE TYPE	KIT REQUIREMENT/NOTES
Chevrolet-Oldsmobile-Buick-Pontiac-Cadillac-Saturn	
1981 and Older .....	No Kit Required
1982 and Newer .....	AX-93-FCGM
Chevrolet-GMC Full Size Vans	
1987 and Older .....	No Kit Required
1988 and Newer .....	AX-88-CHV
Chevrolet-GMC Full Size Pickups	
1987 and Older .....	No Kit Required
1988 and Newer .....	AX-88-CHT
Chrysler-Dodge-Plymouth	
U.S. Built 1974 and Newer .....	AX-93-FCGM
Imported .....	Refer to In-Store Chart
Ford-Lincoln-Mercury	
1984 and Older .....	No Kit Required
1985 through 1990 .....	AX-93-FCGM
1991 and Newer .....	AX-88-SNP
AMC-Jeep-Eagle	
1971 and Newer .....	No Kit Required

## IMPORT CARS

Due to the wide variety of import cars and the different installations required, this manual does not show specific installations in these vehicles. However, this sound system can be installed in many import cars by following the "Universal Installation" section on pages 3 and 4. Check the application chart at your retail store or call our toll-free "HELP" line for specific information on your particular car.

### IMPORTS:

Acura-Audi-BMW-Daihatsu-Fiat-Honda-Hyundai	
Mercedes-Peugeot-Porsche-Saab-Subaru	
Volkswagen-Volvo-Yugo .....	Will Fit Most Years; Some Require AX-88-SNP Kit *
Datsun-Nissan (Most Models)	
1982 and Newer .....	Will Fit Most Years; Some Require AX-88-NAB Kit *
Mazda (Most Models)	
1986 and Newer .....	Will Fit Most Years; Some Require AX-87-MAZ Kit *
Toyota (Most Models)	
1982 and Newer .....	Will Fit Most Years; Some Require AX-88-TOY Kit *

\* Refer to In-Store Chart to determine if kit is required.

For vehicles not listed or more specific information, refer to the in-store application chart or call our "HELP" line.

## UNIVERSAL INSTALLATION FOR VEHICLES WITH AN EXISTING RADIO OPENING

This installation is designed for cars, trucks, vans, and boats that have an existing radio opening. It can also be used as an option on some of the vehicles listed as requiring the AX-88-SNP kit. It will not work on all vehicles, but can be used on most newer Fords and many imports.

1. Inspect the Existing Radio Opening:
  - A. Use the trimplate supplied with the radio to cover the existing opening. If it completely covers the opening, you can install the radio as explained below. If it does not cover the opening, you will need an installation kit.
  - B. Check that there will be sufficient space behind the dashboard for the radio chassis.
2. Wire the Radio to the Vehicle's Wiring:
  - A. In most cases it is easier to wire the radio before mounting it. Place the radio near the dashboard so the wires can be led through the opening.
  - B. Carefully follow the diagrams on pages 10 and 11 or 12 (depending on how many speakers you are using) to wire the radio, making certain all connections are secure and insulated with wire nuts or electrical tape to insure proper operation of the unit.
  - C. After completing the wiring, turn the unit on to confirm operation (ignition switch must be "on"). If unit does not operate, re-check all wiring until problem is corrected. Once proper operation is achieved, turn off unit and ignition switch, and proceed with final mounting of the radio.
3. Mounting the Radio:
  - A. Thread a shaft nut half-way down each radio shaft.
  - B. Place a metal back-up plate on each radio shaft against the shaft nut.
  - C. Position the radio behind the dashboard opening so that the back-up plates are snug against the back of the opening. Adjust the shaft nuts behind the back-up plates so that the desired amount of radio extends through the opening. If possible, the best appearance is usually achieved when there is enough of the radio extending to be flush with the front of the trimplate.
  - D. Place the trimplate over the front of the radio and secure it with a shaft nut on each radio shaft.
  - E. Attach one end of the perforated support strap (supplied) to the screw stud on the radio using the hex nut provided. Fasten the other end of the perforated strap to a secure part of the dashboard either above or below the radio using the screw and nut provided. Bend the strap to position it as necessary.

**CAUTION:** The rear of the radio must be supported with the strap to prevent damage to the dashboard from the weight of the radio or improper operation of the radio due to vibration.

  - F. Install knobs on radio shafts.

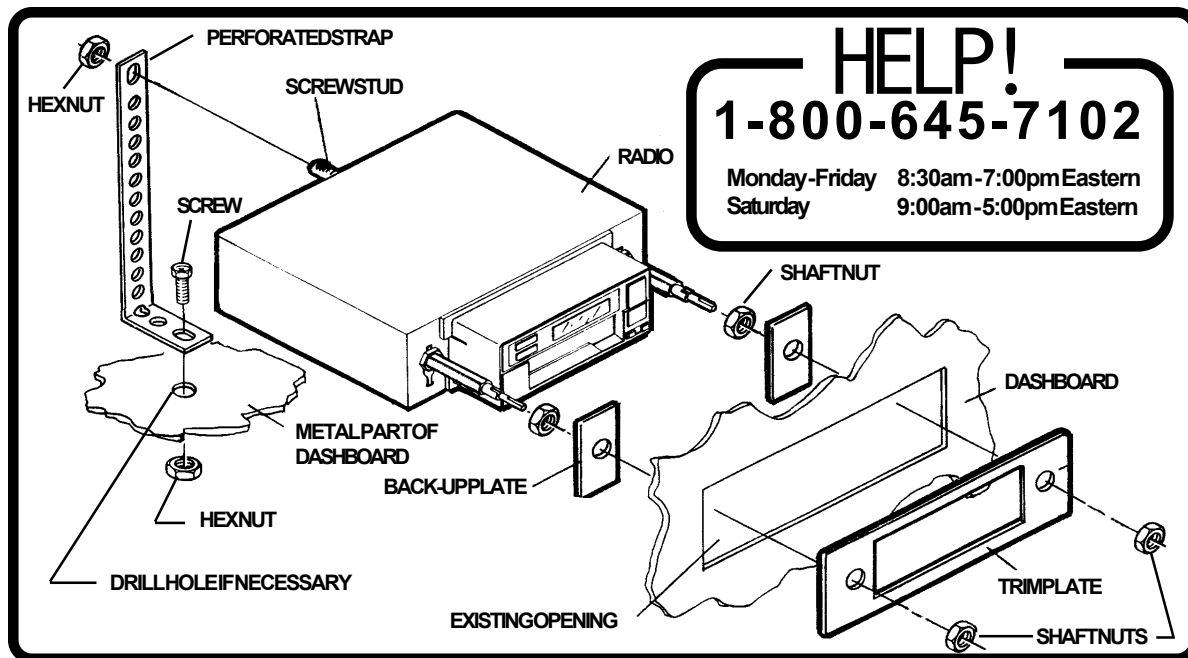

## UNIVERSAL INSTALLATION FOR VEHICLES WITHOUT AN EXISTING RADIO OPENING

This installation is designed for cars, trucks, vans, and boats that do not have an existing radio opening. It will require cutting an opening in a surface of the vehicle, so it is important to mark and measure carefully.

### 1. Select the Mounting Area:

- Using the trimplate supplied, verify that there will be sufficient space on the selected mounting surface.
- Check that there will be sufficient space behind the dashboard for the radio chassis.

### 2. Cut the Required Opening:

- Using the trimplate as a template, place it on the selected mounting surface and mark the 2 shaft holes and nosepiece opening that will need to be cut.
- Carefully cut the 3 holes using a drill and keyhole saw as appropriate. File edges of the openings to remove any burrs.

### 3. Wire the Radio to the Vehicle's Wiring:

- In most cases it is easier to wire the radio before mounting it. Place the radio near the dashboard so the wires can be led through the opening.
- Carefully follow the diagrams on pages 10 and 11 or 12 (depending on how many speakers you are using) to wire the radio, making certain all connections are secure and insulated with wire nuts or electrical tape to insure proper operation of the unit.
- After completing the wiring, turn the unit on to confirm operation (ignition switch must be "on"). If unit does not operate, re-check all wiring until problem is corrected. Once proper operation is achieved, turn off unit and ignition switch, and proceed with final mounting of the radio.

### 4. Mounting the radio:

- Thread a shaft nut half-way down each radio shaft.
- Place a metal back-up plate on each radio shaft against the shaft nut.
- Position the radio behind the dashboard opening so that the back-up plates are snug against the back of the opening. Adjust the shaft nuts behind the back-up plates so that the desired amount of radio extends through the opening. If possible, the best appearance is usually achieved when there is enough of the radio extending to be flush with the front of the trimplate.
- Place the trimplate over the front of the radio and secure it with a shaft nut on each radio shaft.
- Attach one end of the perforated support strap (supplied) to the screw stud on the radio using the hex nut provided. Fasten the other end of the perforated strap to a secure part of the dashboard either above or below the radio using the screw and nut provided. Bend the strap to position it as necessary.

**CAUTION:** The rear of the radio must be supported with the strap to prevent damage to the dashboard from the weight of the radio or improper operation of the radio due to vibration.

- Install knobs on radio shafts.

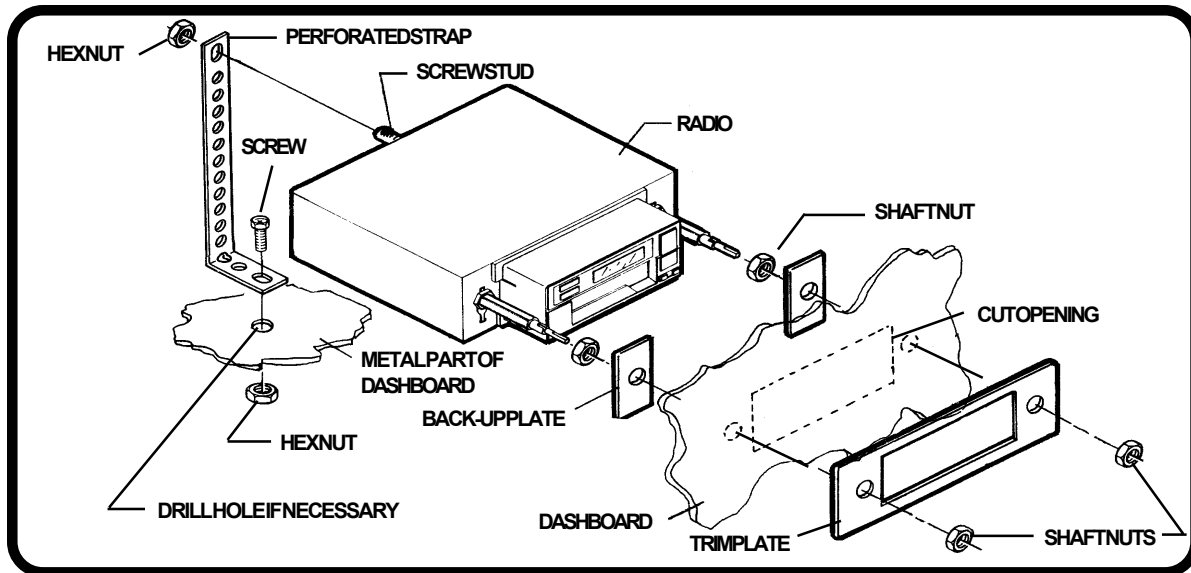



## CHEVROLET-OLDSMOBILE-BUICK-PONTIAC-GMC-CADILLAC INSTALLATION 1981 AND OLDER

**Important-**This installation is designed for 1981 and older U.S. made GM cars, trucks, and vans. For 1981 and newer vehicles, an installation kit may be required. See Kit Listing on Page 2 of this manual or refer to the in-store application chart. If a kit is not required, use the following instructions.

### 1. Remove Existing Radio:

- Remove radio knobs and shaft nuts behind the knobs.
- Locate and remove support brace at back of radio.
- Push radio back into dashboard to access the wiring and antenna cables plugged into the rear of the chassis.
- Un-plug the wiring harness(es) and antenna cable and remove the radio.

### 2. Wire the New Radio:

- In most cases it is easier to wire the radio before mounting it. Place the radio near the dashboard so the wires can be led through the opening.
- Carefully follow the diagrams on pages 10 and 11 or 12 (depending on how many speakers you are using) to wire the radio, making certain all connections are secure and insulated with wire nuts or electrical tape to insure proper operation of the unit.
- After completing the wiring, turn the unit on to confirm operation (ignition switch must be "on"). If unit does not operate, re-check all wiring until problem is corrected. Once proper operation is achieved, turn off unit and ignition switch, and proceed with final mounting of the radio.

### 3. Install the New Radio:

- Thread a shaft nut half-way down each radio shaft.
- Trim the top edge off of the nosepiece collar at the "CUT OFF FOR GM" mark and place the collar on radio nosepiece.
- Place the radio behind dashboard and through the radio opening. Adjust the position of the shaft nuts so that the radio nosepiece and collar are flush against the back of the dashboard.
- Secure the radio with a shaft nut on each radio shaft.
- Attach one end of the perforated support strap (supplied) to the screw stud on the radio using the hex nut provided. Fasten the other end of the perforated strap to a secure part of the dashboard either above or below the radio using the screw and nut provided. Bend the strap to position it as necessary.

**CAUTION:** The rear of the radio must be supported with the strap to prevent damage to the dashboard from the weight of the radio or improper operation of the radio due to vibration.

- Install knobs on radio shafts.

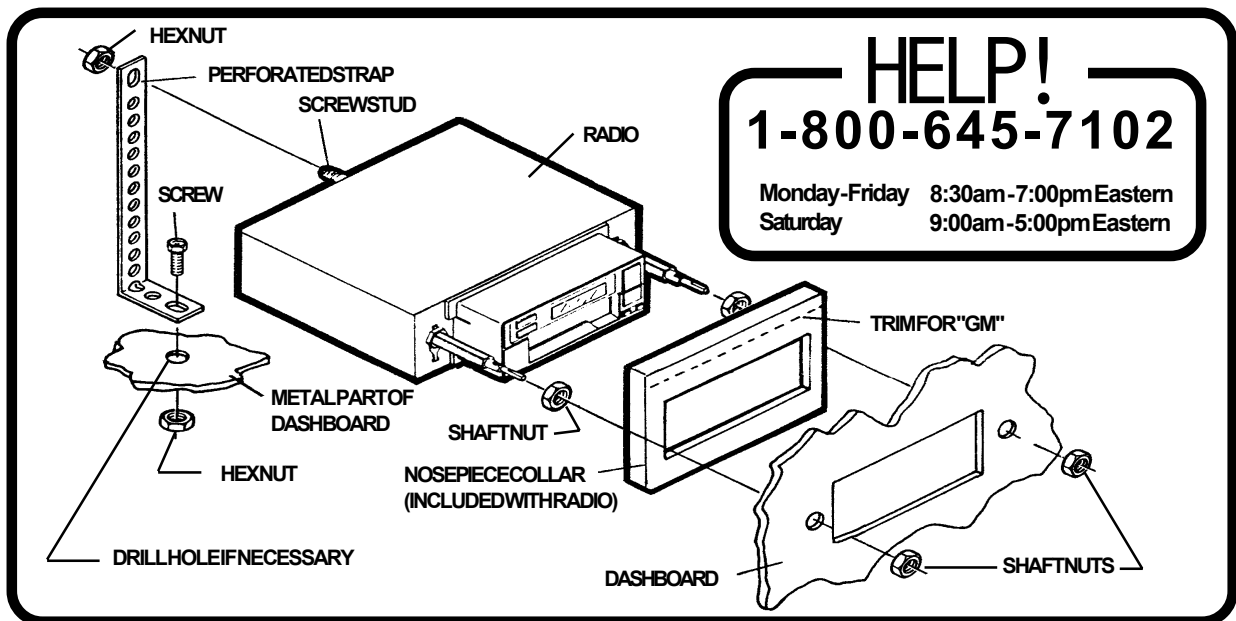

## CHEVROLET-OLDSMOBILE-BUICK-PONTIAC-GMC-CADILLAC-SATURN INSTALLATION 1982 AND NEWER

**Important**-This installation is designed for most 1982 and newer GM cars, trucks, and vans where an installation kit is required. See Kit Listing on Page 2 of this manual or refer to the in-store application chart. If a kit is not required, use the instructions on Page 5.

### 1. Remove Existing Radio:

- Remove the existing dashboard trimpanel surrounding the radio opening. This panel is usually secured by screws and/or snap-in clips.
- Remove the screws used to secure the radio to the sub-dashboard.
- Pull the radio forward to access the wiring and antenna cables plugged into the rear of the chassis.
- Un-plug the wiring harness(es) and antenna cable and remove the radio.

### 2. Install the New Radio:

- Follow the instructions included with the installation kit to attach the radio to the mounting plate supplied with the kit.
- Place the radio near the dashboard so the wires can be led through the opening and following the instructions of Step 2 on Page 5, carefully wire the radio making certain all connections are secure and insulated and confirm proper operation.
- Install the radio/mounting plate assembly to the sub-dashboard according to instructions of installation kit.
- Attach one end of the perforated support strap (supplied) to the screw stud on the radio using the hex nut provided. Fasten the other end of the perforated strap to a secure part of the dashboard either above or below the radio using the screw and nut provided. Bend the strap to position it as necessary.

**CAUTION:** The rear of the radio must be supported with the strap to prevent damage to the dashboard from the weight of the radio or improper operation of the radio due to vibration.

- Replace the dashboard trimpanel.
- Install knobs on radio shafts.

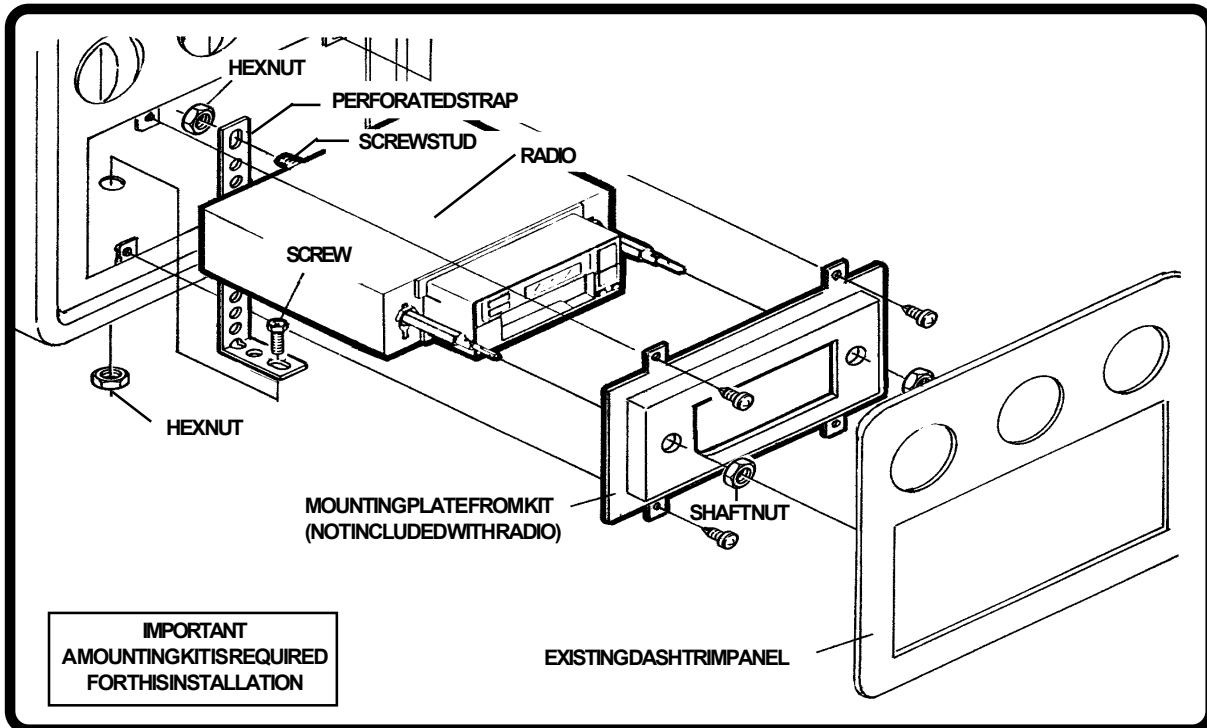

## FORD-LINCOLN-MERCURY INSTALLATION - 1984 AND OLDER

**Important**-This installation is designed for 1984 and older U.S. made Ford cars, trucks, and vans. For newer vehicles, an installation kit may be required. See Kit Listing on Page 2 of this manual or refer to the in-store chart.

### 1. Remove Existing Radio:

- A. Remove radio knobs and shaft nuts behind the knobs.
- B. Locate and remove support brace at back of radio.
- C. Push radio back into dashboard to access the wiring and antenna cables plugged into the rear of the chassis.
- D. Un-plug the wiring harness(es) and antenna cable and remove the radio.

### 2. Wire the New Radio:

- A. In most cases it is easier to wire the radio before mounting it. Place the radio near the dashboard so the wires can be led through the opening.
- B. Carefully follow the diagrams on pages 10 and 11 or 12 (depending on how many speakers you are using) to wire the radio, making certain all connections are secure and insulated with wire nuts or electrical tape to insure proper operation of the unit.
- C. After completing the wiring, turn the unit on to confirm operation (ignition switch must be "on"). If unit does not operate, re-check all wiring until problem is corrected. Once proper operation is achieved, turn off unit and ignition switch, and proceed with final mounting of the radio.

### 3. Install the New Radio:

- A. Thread a shaft nut halfway down each radio shaft.
- B. Place the nosepiece collar on the radio nosepiece.
- C. Place the radio behind dashboard and through the radio opening. Adjust the position of the shaft nuts so that the radio nosepiece and collar are flush against the back of the dashboard.
- D. Secure the radio with a shaft nut on each radio shaft.
- E. Attach one end of the perforated support strap (supplied) to the screw stud on the radio using the hex nut provided. Fasten the other end of the perforated strap to a secure part of the dashboard either above or below the radio using the screw and nut provided. Bend the strap to position it as necessary.

**CAUTION:** The rear of the radio must be supported with the strap to prevent damage to the dashboard from the weight of the radio or improper operation of the radio due to vibration.

- F. Install knobs on radio shafts.

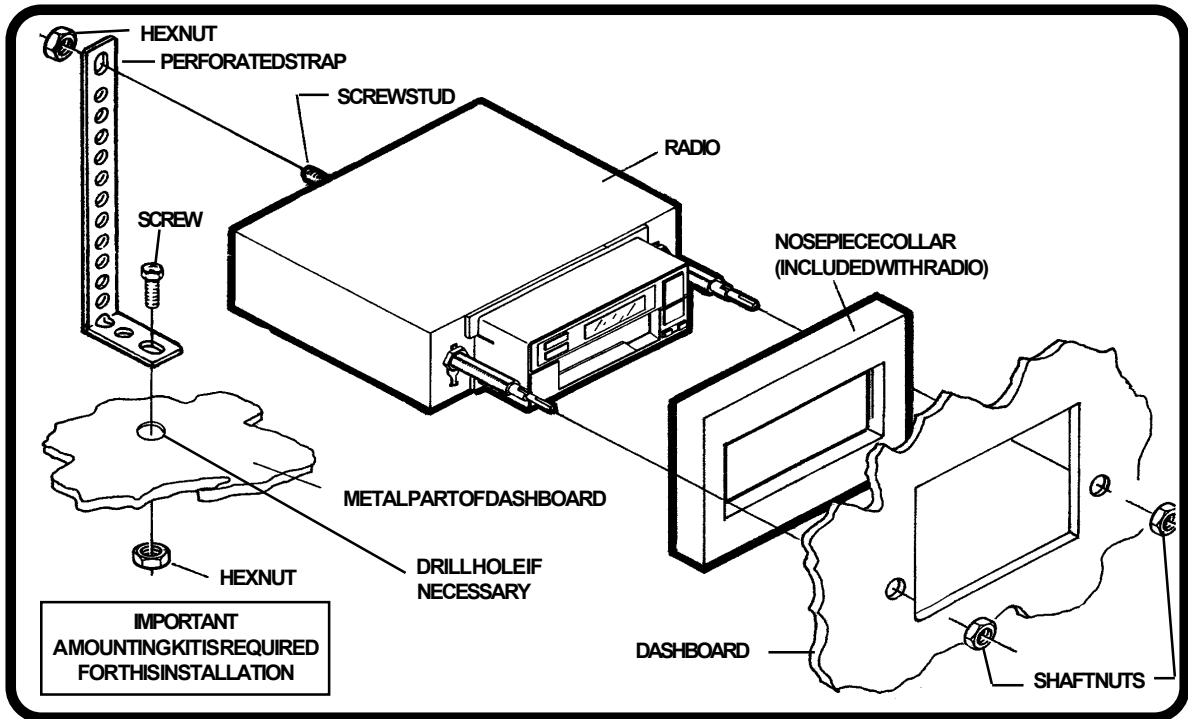



## FORD-LINCOLN-MERCURY INSTALLATION - 1985 AND NEWER

**Important**-This installation is designed for most 1985 through 1990 U.S. made Ford cars, and vans and an installation kit is required for these vehicles. See Kit Listing on Page 2 of this manual or refer to the in-store application chart. For 1991 and newer vehicles, the radio can be installed as shown on Page 3 of this manual or you can use the AX-88-SNP kit. Instructions for use of the AS-88-SNP kit are included with the kit and are not shown in this manual.

### 1. Remove Existing Radio:

- A. Remove existing dashboard trimpanel surrounding the radio opening. This panel is usually secured by screws and/or snap-in clips.
- B. Remove the screws used to secure radio to the sub-dashboard.
- C. Pull the radio forward to access the wiring and antenna cables plugged into the rear of the chassis.
- D. Un-plug the wiring harness(es) and antenna cable and remove the radio.

### 2. Install the New Radio:

- A. Follow the instructions included with the installation kit to attach the radio to the mounting plate supplied with the kit.
- B. Place the radio near the dashboard so the wire can be led through the opening and following the instructions of Step 2 on Page 7, carefully wire the radio making certain all connections are secure and insulated and confirm proper operation.
- C. Install the radio/mounting plate assembly to the sub-dashboard according to instructions of installation kit.
- D. Attach one end of the perforated support strap (supplied) to the screw stud on the radio using the hex nut provided. Fasten the other end of the perforated strap to a secure part of the dashboard either above or below the radio using the screw and nut provided. Bend the strap to position it as necessary.

**CAUTION:** The rear of the radio must be supported with the strap to prevent damage to the dashboard from the weight of the radio or improper operation of the radio due to vibration.

- E. Replace the dashboard trimpanel.
- F. Install knobs on radio shafts.

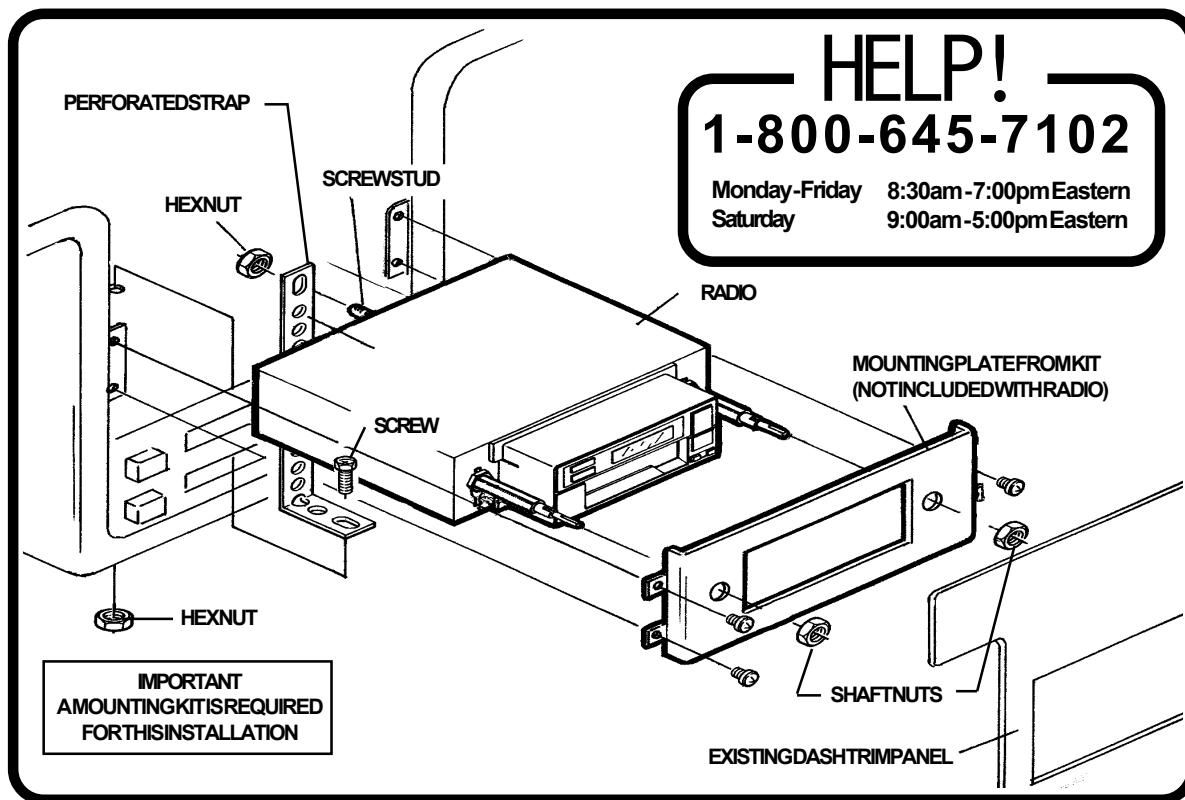

**CHRYSLER-DODGE-PLYMOUTH INSTALLATION**

**ALL U.S. MADE CARS, TRUCKS, AND VANS BUILT SINCE 1974**

**Important**-This radio cannot be installed in any U.S. made Chrysler, Dodge, or Plymouth vehicle without an installation kit. Refer to the Kit Listing on Page 2 for the required kit. Complete kit installation is explained in the instructions included with the kit.

**1. Remove Existing Radio:**

- A. Remove the existing dashboard trimpanel surrounding the radio opening. This panel is usually secured by screws and/or snap-in clips.
- B. Remove the two large screws used to secure radio to the sub-dashboard.
- C. Pull the radio forward to access the wiring and antenna cables plugged into the rear of the chassis.
- D. Un-plug the wiring harness(es) and antenna cable and remove the radio.

**2. Install the New Radio:**

- A. Follow the instructions included with the installation kit to attach the radio to the mounting plate supplied with the kit.
- B. Place the radio near the dashboard so the wires can be led through the opening and following the instructions of Step 2 on Page 3, carefully wire the radio making certain all connections are secure and insulated and confirm proper operation.
- C. Install the radio/mounting plate assembly to the sub-dashboard according to instructions of installation kit.
- D. Attach one end of the perforated support strap (supplied) to the screw stud on the radio using the hex nut provided. Fasten the other end of the perforated strap to a secure part of the dashboard either above or below the radio using the screw and nut provided. Bend the strap to position it as necessary.

**CAUTION:** The rear of the radio must be supported with the strap to prevent damage to the dashboard from the weight of the radio or improper operation of the radio due to vibration.

- E. Replace the dashboard trimpanel.
- F. Install knobs on radio shafts.

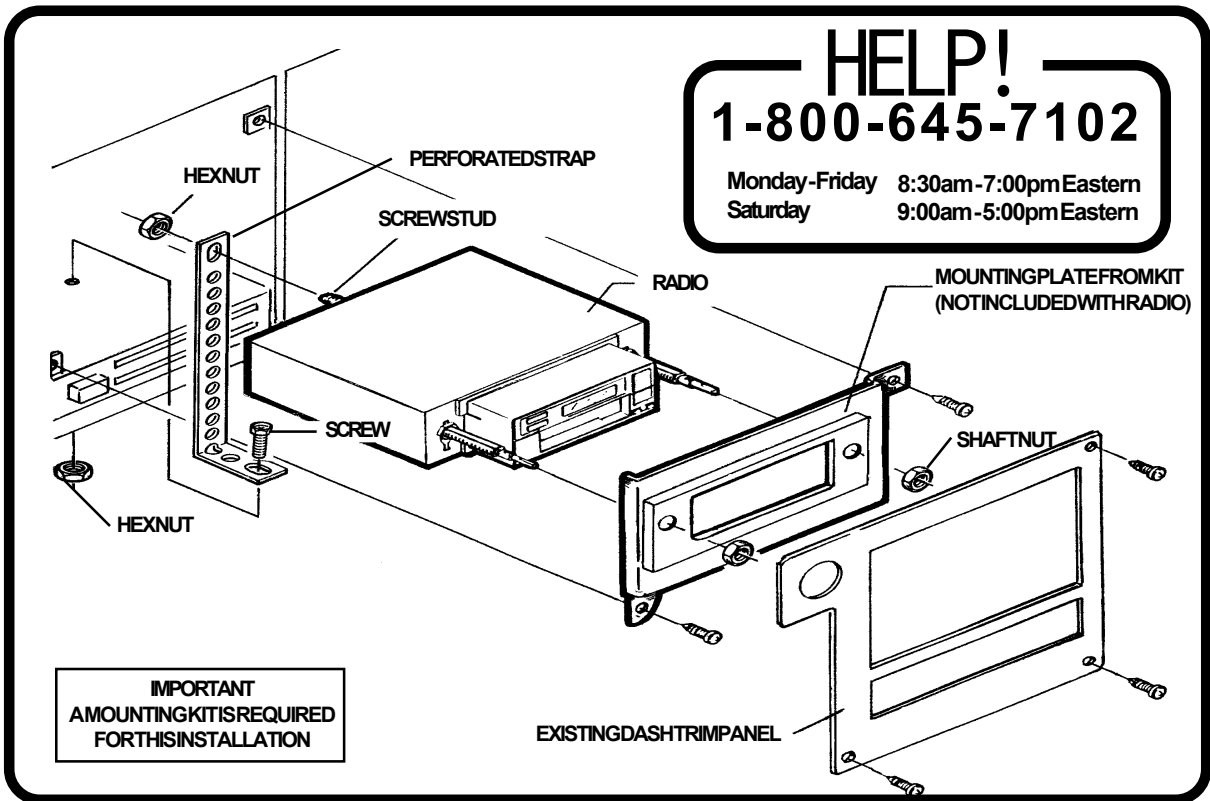

# RADIO WIRING

REFER TO PAGE 11 OR 12 FOR SPEAKER WIRING

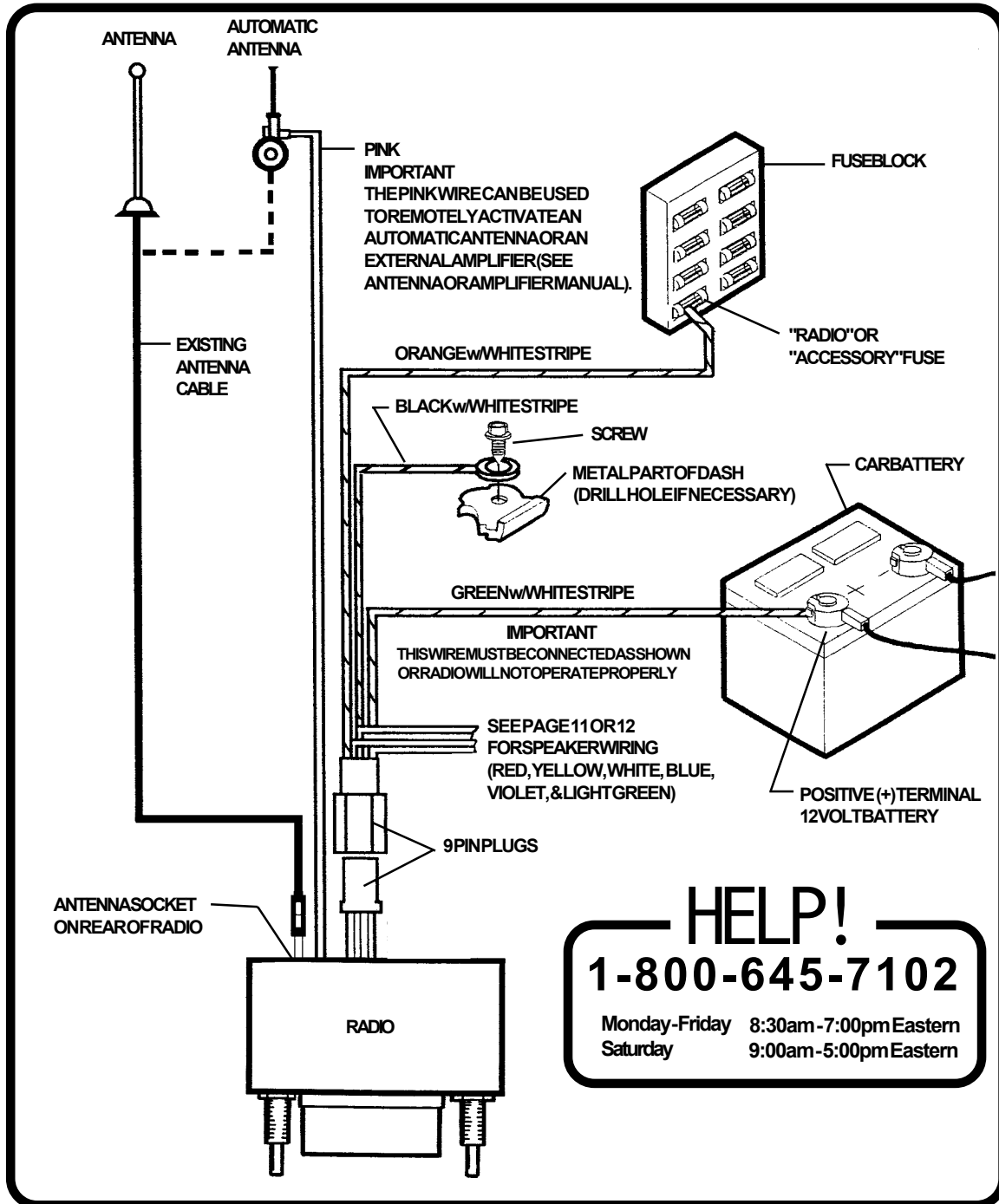

## SPEAKER WIRING - 2 SPEAKER SYSTEMS

REFERTOPAGE10  
FORRADIOWIRING

**WARNING!**

NEVERGROUNDNEGATIVESPEAKERLEADSTOCHASSISGROUND.  
FAILURETOWIREEXACTLYASSHOWNBELWOMAYCAUSEELECTRICAMDAMAGETOTHERADIO.

**HELP!**  
**1-800-645-7102**

Monday-Friday 8:30am-7:00pm Eastern  
Saturday 9:00am-5:00pm Eastern

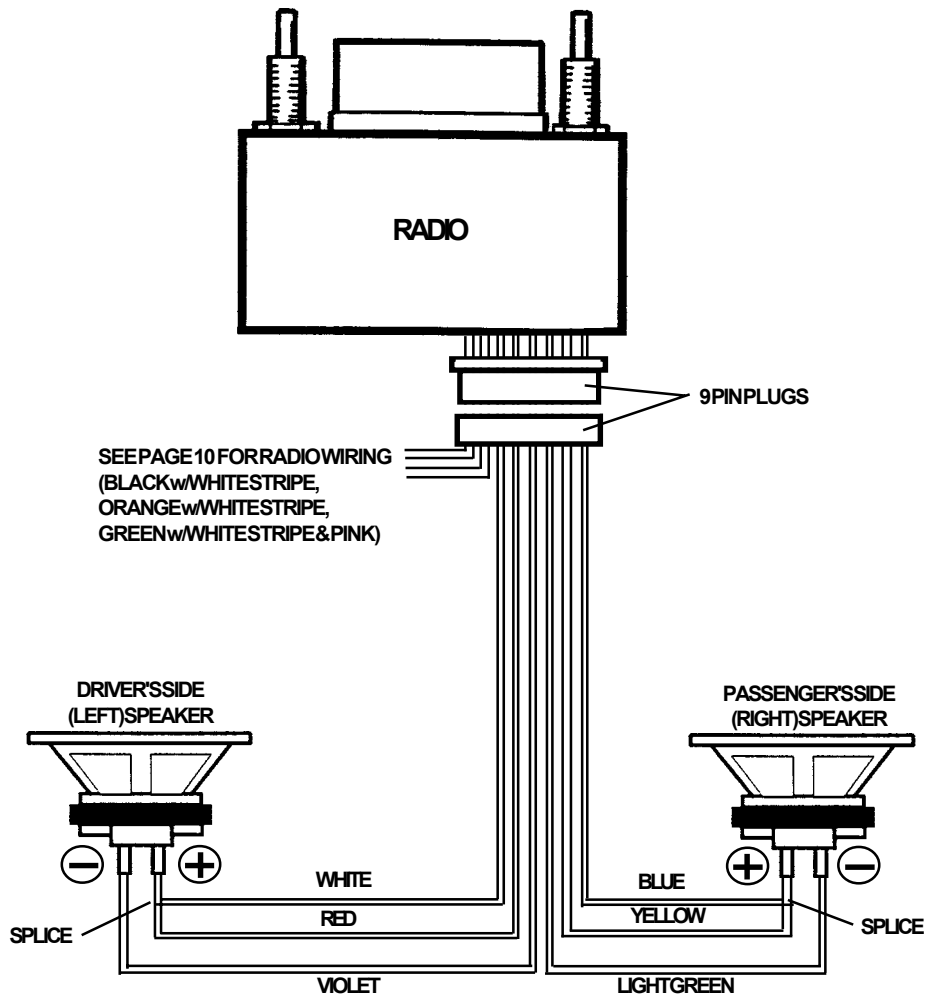

# SPEAKER WIRING - 4 SPEAKER SYSTEMS

REFERTOPAGE10  
FORRADIOWIRING

## WARNING!

NEVERGROUNDNEGATIVESPEAKERLEADSTOCHASSISGROUND.  
FAILURETOWIREEXACTLYASSHOWNBELOWMAYCAUSEELECTRICDAMAGETOTHERADIO.

# HELP!

## 1-800-645-7102

Monday-Friday 8:30am-7:00pm Eastern  
Saturday 9:00am-5:00pm Eastern

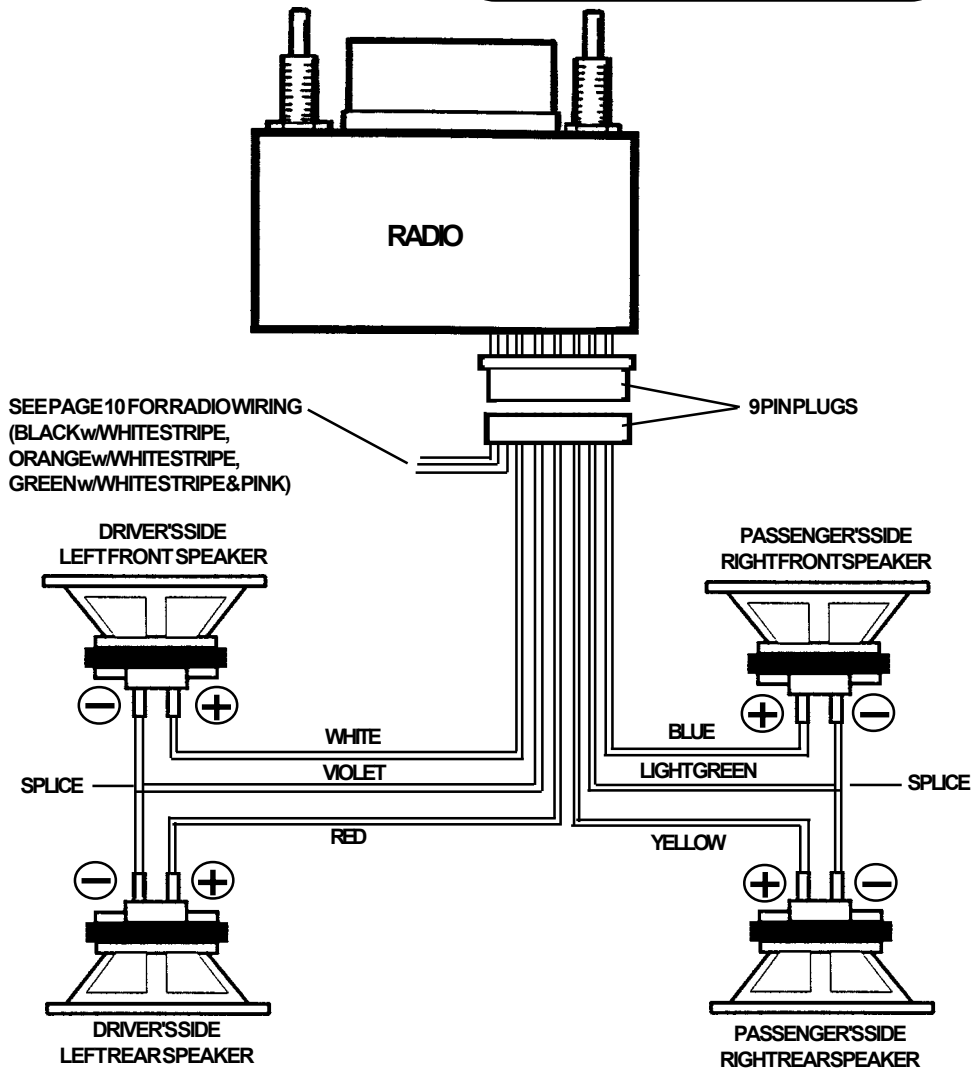

**OPERATING INSTRUCTIONS**

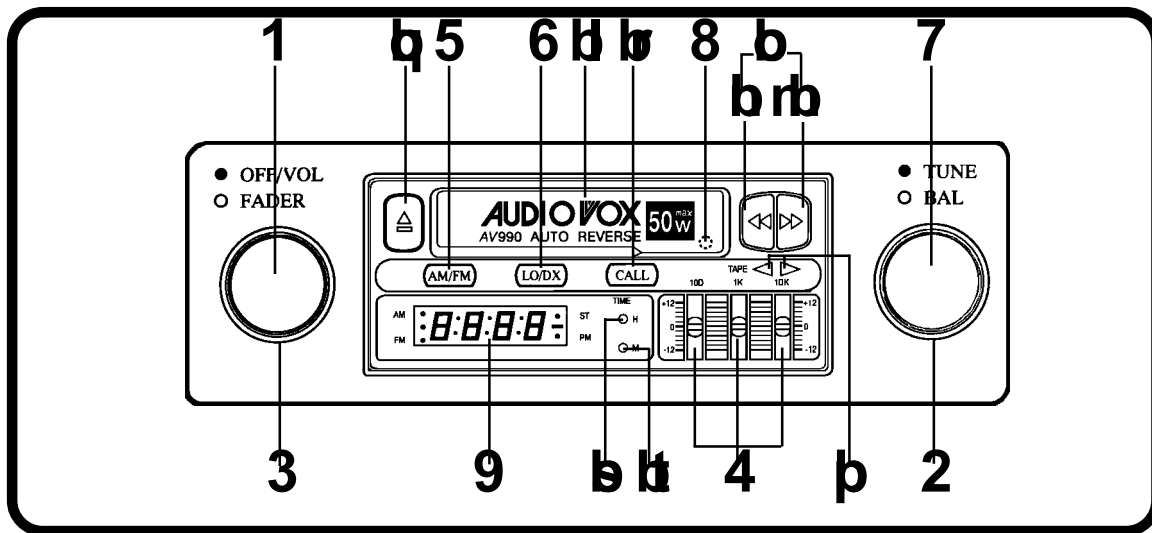

**1 ON-OFF SWITCH/VOLUME CONTROL**

Rotate this knob to the right to turn the unit on. Continue rotation until desired volume level is obtained.

**2 LEFT/RIGHT BALANCE CONTROL**

Rotate this knob to the left or right to obtain the desired balance between the left and right channel speakers.

**3 FRONT/REAR FADER CONTROL**

Rotate this knob to the right or left to obtain the desired balance between front and rear speakers in 4 speaker installations. When used in conjunction with the Left/Right Balance Control 2, you have full 4-way stereo balance capability.

**4 3-BAND EQUALIZER CONTROLS**

These controls permit precise tone adjustment in three frequency ranges from bass (100 Hz) to

mid-range (1 KHz) to treble (10 KHz). Moving each control upward will emphasize that range, while moving it downward will de-emphasize that range. Each slide control is capable of varying the response from the mid-position (flat) setting upward by 12 dB or downward by 12 dB, for a total variation of 24 dB.

**5 AM/FM BAND SELECTOR**

Each time this button is pressed, the radio band changes. The selected radio band is shown by the indicator for AM or FM on the display panel.

**6 FM LOCAL/DISTANT SELECTOR**

This two position switch is incorporated to allow maximum reception in both weak and strong FM signal areas. For normal reception conditions when receiving a wide range of signals including weak or distant stations, the switch should be in the released (out) position, which

will allow maximum signal to the receiver. When in an extremely strong (local) signal area, push the switch in to the Local setting. This will eliminate weak signals and suppress overly strong signals so as to avoid overloading the receiver input. When moving out of the strong signal area, return the switch to the Distant (out) setting.

**NOTE:** The Local/Distant Selector only affects FM signals, and will have no effect on AM reception.

## 7 MANUAL TUNING CONTROL

Rotate this knob to the left or right to select a radio station. The selected frequency will be shown by the digital read-out on the display panel.

## 8 AM ANTENNA TRIMMER

It is very important to adjust the Antenna Trimmer for optimum AM reception. The antenna trimmer is located at the back of the cassette deck behind the the tape door. Adjust it as follows:

1. Tune in a weak station around 1400 KHz on the AM band.
2. Push the tape door open and locate the antenna trimmer at the back of the cassette deck.
3. Using a small screwdriver, slowly adjust the trimmer for maximum output from the radio.

**NOTE:** The Antenna Trimmer only affects AM reception, and will have no effect on FM reception. The trimmer only needs to be adjusted when the radio is first installed and at any time a change is made to the vehicle antenna (replacing the mast, etc.).

## 9 DISPLAY PANEL

The digital display of the radio frequency and time are shown on this panel as well as indicators for AM, FM, and stereo reception.

### **bl** CASSETTE DOOR

Hold the cassette with the exposed tape edge to the right and insert it into the cassette door. Depress fully until the cassette is engaged and begins playing. When the cassette reaches the end of the side of the tape being played, the unit will automatically change direction of play, as shown by the Tape Direction Indicators **bp**, and play the other side of the cassette.

### **bm** FAST-FORWARD BUTTON (FF)

Pushing the Fast-Forward button will cause the tape to move rapidly in the forward direction of play. To stop Fast-Forward movement, lightly push the Rewind button **bn** until the Fast-Forward button disengages.

### **bn** REWIND BUTTON (REW)

Pushing the Rewind button will cause the tape to move rapidly in the reverse direction of play. To stop Rewind movement, lightly push the Fast-Forward button **bm** until the Rewind button disengages.

### **bo** PROGRAM SELECTOR

To manually reverse tape direction and play the other side of the cassette, lightly push both the Fast-Forward **bm** and Rewind **bn** buttons at the same time. The change of direction will be shown by the Tape Direction Indicators **bp**.

### **bp** TAPE DIRECTION INDICATORS

These arrows show the direction of tape play and will change when the program is changed either automatically at the end of play on one side of the cassette or manually by the Program Selector **bo**.

**bq EJECT BUTTON (▲)**

Tape playback is stopped and the cassette is ejected by pressing this button, which also has the function of switching over to radio operation.

**NOTE:** Never leave a cassette engaged in the player when not in use. Doing so can cause damage to the cassette and/or mechanism. Always press the eject button and remove the cassette when leaving the vehicle.

**br DISPLAY CALL SELECTOR (CALL)**

During radio operation, the station frequency will be shown on the display panel. Pressing this button will cause the time to be displayed for 5 seconds before returning to frequency read-out.

During cassette operation, the time will always be shown on the display panel.

**bs HOUR ADJUST BUTTON (H)**

This button is used to adjust the hours on the built-in quartz clock. The button is recessed to prevent accidental engagement so a toothpick, pen point or similar object should be used to activate it.

**bt MINUTE ADJUST BUTTON (M)**

This button is used to adjust the minutes on the built-in quartz clock. The button is recessed to prevent accidental engagement so a toothpick, pen point or similar object should be used to activate it.

---

**SETTING THE CLOCK**

---

1. With the vehicle ignition switch "on", turn the unit off or insert a cassette into the tape door so that the time is showing on the display panel.
2. Using a toothpick, pen point or similar thin object, press the Hour Adjust button **bs** to adjust the hours to the correct setting.
3. Using a toothpick, pen point or similar thin object, press the Minute Adjust button **bt** to adjust the minutes to the correct setting.



## SPECIFICATIONS

Size:	7" W x 2" H x 5-1/2" D 178mm x 50mm x 137mm
Operating Voltage:	12 volts DC, negative ground
Output Power:	50 watts maximum ( 25 watts x 2 channels)
Output Wiring:	Floating-ground type designed for 4 speaker use. May also be used with 2 speakers.
Output Impedance:	Compatible with 4-8 ohm speakers
Tuning Range:	AM: 530-1,720 KHz. FM: 87.5-107.9 MHz.
Sensitivity:	AM: 15 uv. FM: 2.5 uv.
FM Stereo Separation:	30 dB
Tape Frequency Response:	50-10,000 Hz.
Tape S/N Ratio:	50 dB
Wow & Flutter:	0.15% WRMS

\* Specifications are subject to change without notice.

## TROUBLESHOOTING

PROBLEM	PROBABLE CAUSE	CHECK FOLLOWING
Unit completely inoperative no lights, no sound	Incorrect power connection	Orange/White stripe wire to +12V ACC. and Green/White stripe wire to +12V battery
	Blown fuse	Check fuses in wires listed above and check car fuse block
Unit will not keep time or Radio station memory (Electronic Tuning Radios Only)	Incorrect power connection	Green/White Stripe wire is not connected to a "live" +12V battery source
	Blown fuse	Check fuse in Green/White stripe wire and at car's fuse block
Noise on both radio and tape	Poor ground	Check Black/White stripe wire for proper grounding
	Dirty or corroded battery posts	Clean and tighten connection
	If problem also existed with previous radio you removed	Consult your local garage mechanic-car may need tune-up or noise filter
Noise on radio only	Antenna	Check that antenna base is grounded. Test with antenna disconnected. If noise goes away, replace antenna
Poor FM reception and almost no AM reception	Antenna	Replace antenna and antenna cable
Poor FM reception and Good AM reception	FM Local-Distant switch	Check if unit has a Local-Distant switch and set to "Distant" position
No sound on one speaker (both radio and tape)	Wiring	Check speaker wiring
	Speaker	Test with good speaker
	Radio Operation	Check balance and fader controls
Poor sound on tape only (after one month or more of tape usage)	Dirty tape mechanism	Clean tape head and mechanism
Poor sound-new unit	For radios with 40 watts or more output power	Check rating of speakers for sufficient power capacity
		Check that speakers are in good condition
		Check that Violet and Green speaker wires are not grounded
	Wiring	Check speaker wiring

## CARE AND MAINTENANCE

The radio portion of your new sound system does not require any maintenance. We recommend you keep this manual for future reference on how to set the clock (on units with a clock) and for general reference of the many features found in this unit.

As with any cassette player, the cassette section of this sound system does require a minimum of maintenance to keep it in good working condition. The following simple care and maintenance suggestions should be followed to prevent malfunctions of the cassette system.

### CassetteCare:

1. Purchase a cassette cleaning kit from your local retail store. Use it! At least every 20 to 30 hours of operation you must clean the cassette mechanism. A dirty cassette player will have a poor sound.
2. Do not use cassettes that exceed 45 minutes of play on each side.
3. Do not insert a cassette that appears to be broken, twisted or dirty or with loose or torn labels on it.
4. Always keep your cassettes away from direct sunlight or exposure to sub-freezing conditions. If a cassette is cold, allow it to warm up before use.
5. Do not keep a cassette in the player when not in use.
6. Before inserting a cassette in the player, check that the tape is tightly wound on the reels. Take up any excess slack using a pencil to turn the drive hub in the cassette (see diagram below).

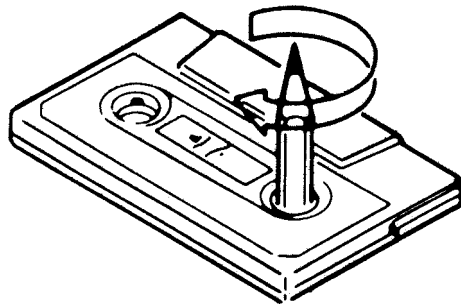

## 12 MONTH LIMITED WARRANTY

**Applies to In-dash radios, radio/tape player and radio/CD player combinations, and CD Changers.**

AUDIOVOX CORPORATION (the Company) warrants to the original retail purchaser of this product that should this product or any part thereof, under normal use and conditions, be proven defective in material or workmanship within 12 months from the date of original purchase, such defect(s) will be repaired or replaced with new or reconditioned product (at the Company's option) without charge for parts and repair labor.

To obtain repair or replacement within the terms of this Warranty, the product is to be delivered with proof of warranty coverage (e.g. dated bill of sale), specification of defect(s), transportation prepaid, to an approved warranty station. For the location of the nearest warranty station to you, call toll-free to our control office:

**IN U.S.A. 1-800-243-1311**  
**IN CANADA 1-800-645-4994**

This Warranty does not extend to the elimination of car static or motor noise, to correction of antenna problems, to costs incurred for installation, removal, or reinstallation of the product, or damage to tapes, compact discs, speakers, accessories, or vehicle electrical systems.

This Warranty does not apply to any product or part thereof which, in the opinion of the Company, has suffered or been damaged through alteration, improper installation, mishandling, misuse, neglect, accident, or by removal or defacement of the factory serial number/bar code label(s). THE EXTENT OF THE COMPANY'S LIABILITY UNDER THIS WARRANTY IS LIMITED TO THE REPAIR OR REPLACEMENT PROVIDED ABOVE AND, IN NO EVENT, SHALL THE COMPANY'S LIABILITY EXCEED THE PURCHASE PRICE PAID BY PURCHASER FOR THE PRODUCT.

This Warranty is in lieu of all other express warranties or liabilities. ANY IMPLIED WARRANTIES, INCLUDING ANY IMPLIED WARRANTY OF MERCHANTABILITY, SHALL BE LIMITED TO THE DURATION OF THIS WRITTEN WARRANTY. ANY ACTION FOR BREACH OF ANY WARRANTY HEREUNDER INCLUDING ANY IMPLIED WARRANTY OF MERCHANTABILITY MUST BE BROUGHT WITHIN A PERIOD OF 30 MONTHS FROM DATE OF ORIGINAL PURCHASE. IN NO CASE SHALL THE COMPANY BE LIABLE FOR ANY CONSEQUENTIAL OR INCIDENTAL DAMAGES FOR BREACH OF THIS OR ANY OTHER WARRANTY, EXPRESS OR IMPLIED, WHATSOEVER. No person or representative is authorized to assume for the Company any liability other than expressed herein in connection with the sale of this product.

Some states do not allow limitations on how long an implied warranty lasts or the exclusion or limitation of incidental or consequential damage so the above limitations or exclusions may not apply to you. This Warranty gives you specific legal rights and you may also have other rights which vary from state to state.

**U.S.A. :** AUDIOVOX CORPORATION, 150 MARCUS BLVD., HAUPPAUGE, NEW YORK 11788 (800) 243-1311

**CANADA:** CALL 1-800-645-4994 FOR LOCATION OF WARRANTY STATION SERVING YOUR AREA

**AUSTRALIA:** AUDIOVOX PACIFIC PTY LTD., DOYLE AVENUE, UNANDERRA, NSW 2526 (042) 718-555

**NEW ZEALAND:** AUDIOVOX PACIFIC PTY LTD., UNIT B, 6 HENDERSON PLACE, PENROSE, AUCKLAND (09) 645-720

Form No. 128-4123D

# AUDIOVOX®

© 1996 Audiovox Corporation 150 Marcus Blvd Hauppauge, NY 11788

Printed in China

Form No. 128-4775

## OUTSIDE BACK COVER